

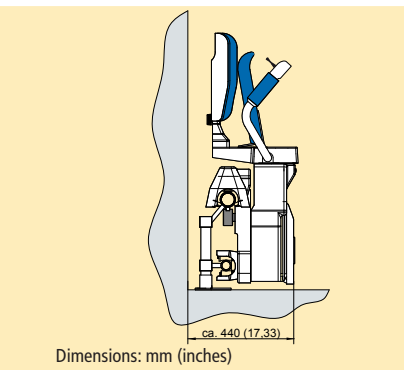

HAWLE STAIRLIFT HW 10 / HW 11 – technical specifications

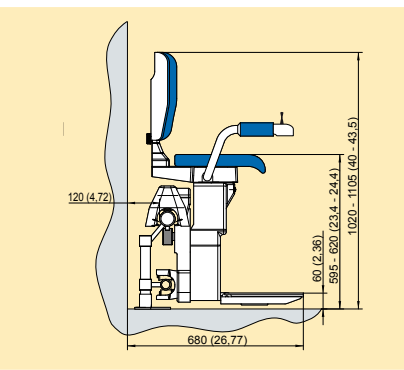
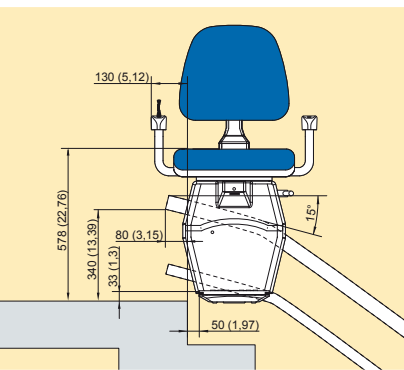
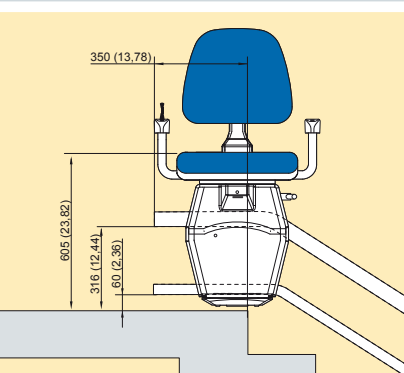

Dimensions: mm (inches)

RAIL

Min. stair width	750 mm (29,53 in)
Rail to wall distance (incl. rail)	ca. 180 mm (approx. 7,09 in)
Rail material	Steel
Tube diameter (upper / lower)	56 mm / 40 mm (2,2 in / 1,57 in)
Max. rail length	ca. 40 m (approx. 130 ft)
Min. rail start distance	340 mm (13,38 in)
Rail fixture	On each 2nd to 4th riser
Wall fixing	optional
Maximum incline	< 75 deg.
Driving speed	< 10 cm / sec. (< 3,9 in / sec.)
Loading capacity	125 kg - 150 kg (< 330 lb)

CHAIR

Standard seat	not pivotable (ASME)
Swivel seat (optional)	manual (ASME) or powered
Chair dimensions:	
Seat height to floor / height footrest	~ 610 mm / 60 mm (24 in / 2,4 in)
Seat height to footrest	550 mm (21,65 in)
Folded out distance to wall	680 mm (26,77 in)
Folded up distance to wall	440 mm (17,33 in)
Seat depth to front of backrest	410 mm (16,15 in)

CONTROL

Joystick (on right or left armrest)	Standard
2-button switch	optional
Key switch (to prevent unauthorized usage)	optional
Radio remote control (2 pcs)	Standard

ENGINE / DRIVE

Engine power	300 Watt
Power supply (100 - 240V, 50 Hz)	Socket (upstairs or downstairs)
Battery operation	yes / 24 V
Mode of driving	Gear rack

Dimensions vary to local structural conditions. Errors excepted and subject to change.
Effective: 2016

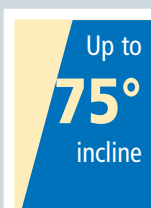

Member of HAWLE GROUP INTERNATIONAL

office@hawle-treppenlifte.de · www.hawle-treppenlifte.de